

# Connex™

## OPC UA Server

- Offers one all-inclusive data source to eliminate islands of automation.
- Provides a large collection of communications protocols to connect to a wide variety of data sources.
- Delivers cross-platform performance with support for Windows and Linux operating systems.
- Enhances IoT capabilities and acts as a gateway to managing communication between field devices and cloud solutions.
- Acts as a data router bringing data in on one protocol and outputting the data to one or more other protocols.
- Provides real-time information collection and recording with support for Historical Access.
- Offers support for Alarms & Conditions to manage alarm notifications for OPC UA clients.
- Helps facilities avoid manufacturer “lock-in.”



### Enhance Communication with Simplified, Open Connectivity

Emerson’s Connex supports a large number of protocols for industries, infrastructures and buildings to deliver seamless and effortless connectivity to field devices in automation and process control. Whether users are deploying a supervisory control project, IoT/analytics project, or simply need a gateway or protocol converter, Connex quickly and intuitively connects a multitude of devices for better data flow. Via its built-in protocol libraries, Connex can collect and publish data to the cloud, manage information flows to business systems, or connect field devices to software applications or to each other effortlessly and safely.

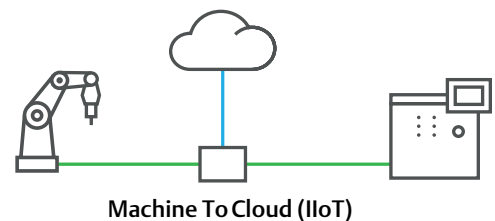
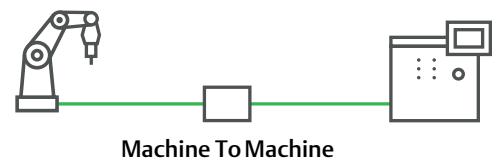
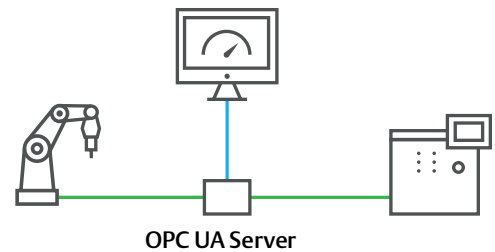

# Connex

Using its built-in drivers, Connex normalizes data to open information technology (IT) and operational technology (OT) protocols, enabling delivery of that data to external devices and applications supporting protocols such as OPC UA and MQTT.

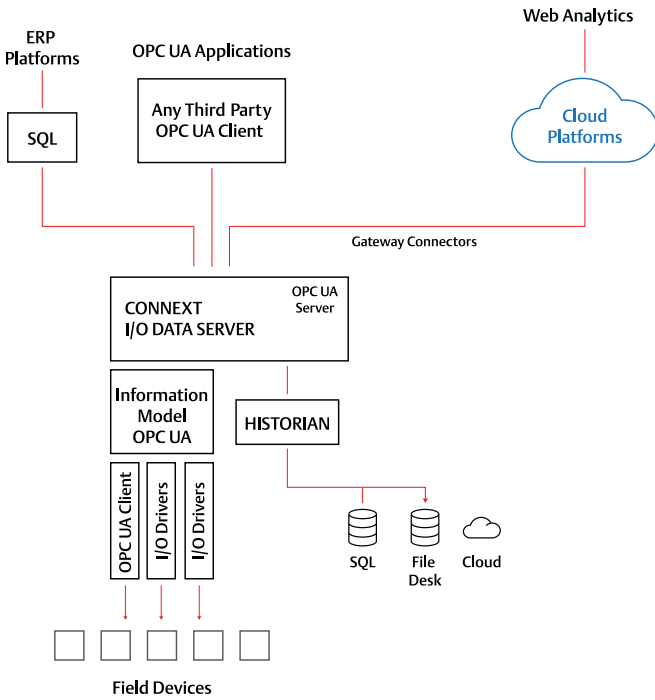

## Eliminate the Need for Custom Scripting with Open Communication

Many industries make equipment decisions based on OEM suppliers, resulting in a facility with equipment from a variety of providers – often using different communication protocols. Over time, the selection of controls vendors may change, leaving facilities with a varying array of different equipment. Connex is designed for just such a heterogeneous environment.

Instead of requiring custom scripting and code to enable communication between disparate equipment, Connex serves as a real-time information collection center and data router, bringing all field device data to one location for normalization and then serving it out to systems such as SCADA, HMI, MES, ERP, cloud analytics, or gateways to other enterprise systems using a common and open protocol.

Connex can connect to most equipment and is extensible for additional protocols. There are many driver packs available for:

- Industrial Automation
- Buildings and Facilities
- Telemetry
- IIoT

And each Connex communication protocol supports automatic tag importing from the field device or PLC for smoother and faster communication and configuration.

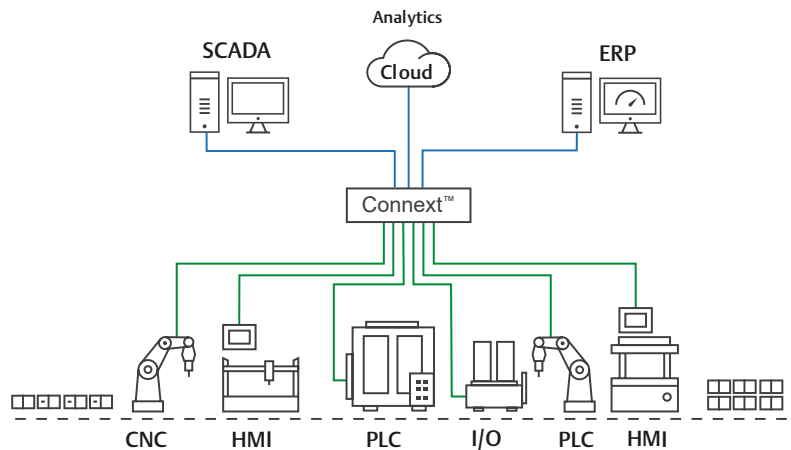

### Cross-Platform Capability

Connex can reside on a Windows or Linux operating system across many hardware configurations.

The same capabilities exist regardless of operating system. The software can be customized ranging from a small, embedded application on a low-cost industrial PC to a large, 100,000+ tag system. Support for multiple systems empowers teams to deploy many small nodes and aggregate them into a single, larger system.

### Ready Out-of-the-Box

The Connex data server requires no custom scripting or coding. Drivers are connected through setup guides enabling users to quickly provide all the details to easily establish connectivity to field equipment, significantly reducing the time to deployment.

### Collect and Store Critical Data

The Connex server can optionally record data directly to a local database or in the cloud using integrated historian and data logger functions. The historian stores data in a time-series format, while the data logger offers data recorded in tables.

Both the historian and data logger interface seamlessly with the most popular databases including SQL Server, MySQL, Oracle and SQL Azure. The server also supports the Historical Access specification to allow OPC UA clients access to historical data.

Connex provides the option to use archive redundancy to deliver increased security for mission critical and fault tolerant applications.

### Certified for Improved Performance

Connex is a certified OPC Foundation I/O server, offering the strongest confirmation of OPC technology and communication model performance. The server not only supports the Data Access specification to exchange data, it also supports the Alarms & Conditions specification to manage alarm notifications for OPC UA clients.

### A Wide, Expanding Array of Drivers

Connex offers support for an extensive variety of communication protocols. Users can select individual drivers or activate them in bulk through pre-compiled driver packs. The most popular drivers are already included, and additional drivers are continuously added.

- Modbus RTU or TCP Master or Slave
- Siemens S7 TCP, S7-MPI, PPI
- Siemens TIA PORTAL
- Rockwell EtherNet/IP
- Omron FINS Ethernet or Ethernet/IP
- Profibus, PROFINET
- Mitsubishi FX, Q Series
- Panasonic FP MEWTOCOL
- SAIA-Burgess
- Beckhoff TwinCAT
- B+R PVI
- GE Ethernet
- Fanuc (CNC)
- IEC 60870-5-104
- IEC 61850
- Lacroix-Sofrel LACBUS
- BacNET/IP
- Konnex – EIB
- SNMP Manager (as Agent)
- OPC UA Azure IoT
- MQTT
- B+R PVI

Additional drivers can be found at:

[www.progea.com/i-o-driver-list-movicon-next/?lang=en](http://www.progea.com/i-o-driver-list-movicon-next/?lang=en)

## Server Requirements (OS Windows)

The table below reports the software and hardware requirements for the server side in Connex projects.

Software Requirements	Hardware Requirements
Minimal OS	CPU Intel® Core™ i3-5xxx (5th generation)
Windows 8.1	RAM: 4 GB
Windows 10 IoT Enterprise	HD: Solid State Disk with 4 GB of free space
Windows Server 2012	Graphic Card: Integrated
Recommended OS	Recommended
Windows 10 (v. 1607)	CPU Intel® Core™ i5-5xxx (5th generation)
Windows Server 2019 (v. 1803)	RAM: 4 GB
Windows Server 2016	HD: Solid State Disk with 4 GB of free space
	Graphic Card: Integrated

## Server Requirements (OS Linux)

The distributions support on Linux are exclusively those compatible with .NET Core such as: Linux (desktop and server versions), Debian, Raspbian.

## Connex

### Americas Support – Technical and Commercial

Phone: 1-888-565-4155 or 1-434-214-8532 (if toll free 800 option is unavailable)

Email for Technical Support: [support.mas@emerson.com](mailto:support.mas@emerson.com)

Email for Commercial Support: [customercare.mas@emerson.com](mailto:customercare.mas@emerson.com)

Primary language of support: English

### Europe, Middle East, & Africa Support – Technical and Commercial

Phone: +800-4-444-8001 or +420-225-379-328

(if toll free 800 option is unavailable or dialing from a mobile telephone)

Email for Technical Support: [support.mas.emea@emerson.com](mailto:support.mas.emea@emerson.com)

Email for Commercial Support: [customercare.emea.mas@emerson.com](mailto:customercare.emea.mas@emerson.com)

Primary languages of support: English, German, Italian, Spanish

### Asia Support – Technical and Commercial

Phone: +86-400-842-8599 for Greater China

+65-3157-9591 (All Other Countries)

Email for Technical Support: [support.mas.apac@emerson.com](mailto:support.mas.apac@emerson.com)

Email for Commercial Support Asia: [customercare.cn.mas@emerson.com](mailto:customercare.cn.mas@emerson.com)

Primary languages of support: Chinese, English

**Support Website:** [www.emerson.com/jiac-support](http://www.emerson.com/jiac-support)

**Home Website:** [www.emerson.com/en-us/automation/control-and-safety-systems/movicon](http://www.emerson.com/en-us/automation/control-and-safety-systems/movicon)

#### United States Office

Emerson Automation Solutions  
Intelligent Platforms, LLC  
2500 Austin Dr  
Charlottesville, VA 22911

#### Brazil Office

Emerson Automation Solutions  
Av. Hollingsworth, 325 – Iporanga  
Sorocaba – SP, 18087-105

#### Australia Office

Emerson Automation Solutions  
471 Mountain Hwy,  
Bayswater VIC 3153, Australia  
+61 3 9721 0200

#### Germany Office

Emerson Automation Solutions  
ICC Intelligent Platforms GmbH  
Memminger Straße 14  
Augsburg, DE 86159

#### Italy Office

Emerson Automation Solutions  
Progea Srl  
Via D' Annunzio 295,  
1-41123 Modena, Italy

#### India Offices

Emerson Automation Solutions  
Intelligent Platforms Pvt. Ltd.,  
Building No.8, Ground Floor  
Velankani Tech Park, No.43  
Electronics City Phase I, Hosur Rd  
Bangalore-560100

#### China Office

Emerson Automation Solutions  
Intelligent Platforms (Shanghai) Co., Ltd  
No.1277, Xin Jin Qiao Rd, Pudong,  
Shanghai, China, 201206

#### Singapore Office

Emerson Automation Solutions  
Intelligent Platforms Asia Pacific Pte. Ltd.  
1 Pandan Cres,  
Singapore, 128461

©2022 Emerson. All rights reserved.

The Emerson logo is a trademark and service mark of Emerson Electric Co. The Movicon logo is a mark of one of the Emerson family of companies. All other marks are property of their respective owners.

The contents of this publication are presented for information purposes only, and while diligent efforts were made to ensure their accuracy, they are not to be construed as warranties or guarantees, express or implied, regarding the products or services described herein or their use or applicability. All sales are governed by our terms and conditions, which are available on request. We reserve the right to modify or improve the designs or specifications of our products at any time without notice.